

Main Features

Precision

- 30~50µm Unidirectional repeatability & Position feedback. (Varied by each stroke version. See spec chart.)
- Absolute position sensing via Potentiometer (No Calibration needed)
- Position feedback
- 32Bit Micro controller, High resolution (4096) A/D converter

Durability

- Heavy Duty Reliable coreless or cored motor
- Smart Overload protection detects jam or over 50% duty-rate (Overridable)
- Life-cycle Reference Data in our homepage (Under 50% duty cycle recommended)
- Vertical (Z axis) use is possible due to mechanical Self-lock (Certain models are not applicable, see the model specification chart)

Easiness

- Compact size for space constraints
- Hassle-free, Built-in drive circuit
- Daisy chain serial connection between servos
- Various mounting solutions
- Detachable and 90° rotatable hinge design (Patented)
- Various APIs / Libraries / Examples of programming languages (C# / C++ / Python / Java / Raspberry Pi / Arduino etc.)
- Dedicated PC Software (Parameter setting & simple motion testing) and PC USB Interface (IR-USB01) available (Optional)
- LED Error indicator & LED self-diagnosis function
- Paired with various controller types (PC / PLC / Arduino / Raspberry-Pi / RC Controller / Dedicated embedded board etc.)

Variety

- Two types of motor choices (Coreless & Cored motor)
- Various Stroke options (26 to 96mm)
- Various Rated Load options (6 to 100N at 12V and 6N/12N at 7.4V)
- Various Speed options (7.7 to 110mm/s at No load condition)
- Two types of data communication options (TTL or RS-485)
- IR Robot open protocol (Download from homepage)
- TTL(Data comm.) or PWM(Pulse signal) is automatically recognized in TTL/PWM version
- Active on custom design orders upon customer's request

Applications

- Medical device and Lab equipment
- Vending and game machines
- Robotics
- Automation (Factory / Home / Agriculture etc)
- Production and inspection jigs
- UAV (Fixed wing / Helicopter / Multicopter etc)
- DIY, Education, Hobby, etc

Model Name System

Feature	Options
M : Motor Type	D : Cored L : Coreless
V : Voltage	7 : 7.4V 12 : 12V
L : Load (Rated)	XXX N (Newton)
C : Communication type	PT : PWM & TTL F : RS-485
S : Stroke	3 : 27mm* 4 : 41mm 6 : 56mm 10 : 96mm

* 27mm can be extended to 30mm using IR-USB01

* Basic stroke for cored motor version is 26mm and to be extended to max. 29mm using IR-USB01

Coreless Motor Line-up

- High force, highly durable coreless motor applied
- Stroke option : 27mm*, 41mm , 56mm, 96mm
- Rated Load option : 12 to 100N
- 12V Motor with 7 ~ 13V input voltage range
- RS-485 or TTL/PWM communication type options
- Metal alloy rod
- Engineering plastic case (27mm stroke version)
- Aluminum stroke case & engineering plastic motor case (41mm / 56mm / 96mm)

* 27mm stroke can be extended to 30mm using IR-USB01



- 1 Rod End Tip (M3)
- 2 Metal Rod (SUS)
- 3 Aluminum stroke case
- 4 LED Indicator
- 5 2 Daisy Chain Connectors
- 6 Hinge (Detachable & Rotatable)
- 7 Engineering plastic case for motor, gear box and drive circuit

Cored Motor Line-up

- Heavy duty cored motor applied
- 26mm stroke (26mm stroke can be extended to 29mm using IR-USB01)
- RS-485 or TTL/PWM communication type options
- Rated Load option : 6N and 12N
- Engineering plastic rod
- Motor Voltage options
 - 7.4V Motor with 6.5 ~ 8.9V input voltage range
 - 12V Motor with 7 ~ 13V input voltage range



PC Software - mightyZAP Manager

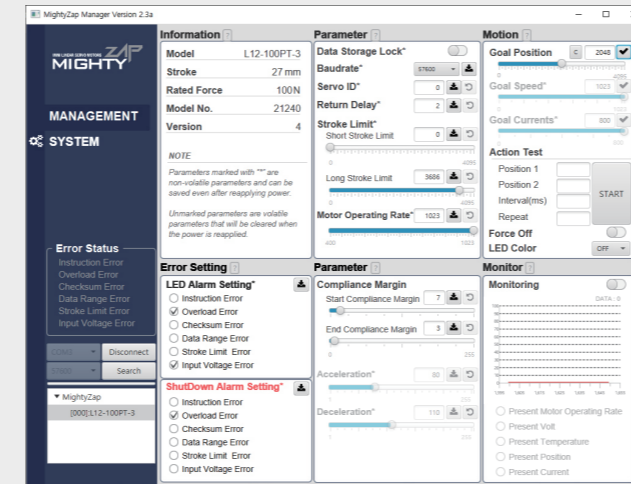

- Setting for various operation parameters & memory parameters
 - Baud rate, ID, Delay, Stroke limit, Motor Operating rate, Goal Position
 - LED Alarm, Overload setting
- Simple Motion Test
- System reset and Firmware update
- Motor Operating rate, Voltage, Temperature, Present position monitoring
- Need optional "PC USB Interface IR-USB01"
- Windows compatible mightyZAP manager software enables user to set various parameters & test motions. (Able to download from our website for free)
- (PC Software will be updated from time to time, so it is recommended for the user to download and update PC software properly.)

Standard Accessories



- 1 Hinge Base 1pc
- 2 Hinge 1pc
- 3 Hinge Shaft 1pc
- 4 Rod End Tip 1pc
- 5 M3 NUT 3pcs
- 6 M2.5x6 Screws 3pcs
- 7 Wire(F Version) : 4Pin Molex to Molex (RS-485)
- 8 Wire(PT Version) : 3Pin Molex to Molex (TTL) & S-02 to Molex (PWM) (S-02 to Molex wire for PWM to be packed in cored motor version only.)
- 9 Socket head M3.0x8 mounting bolt 3pcs (40 to 96mm Stroke line-up only)
- 10 Socket Set Screw 1pc
- 11 Wrench for M3 NUT 1pc

Optional Accessories

Extension Wire IR-EW01~04

We offer extension wires as below for application in your facilities.

- IR-EW01 : **1,000mm** length with **3pins TTL/PWM** Molex connectors (50-37-5033)
- IR-EW02 : **2,000mm** length with **3pins TTL/PWM** Molex connectors (50-37-5033)

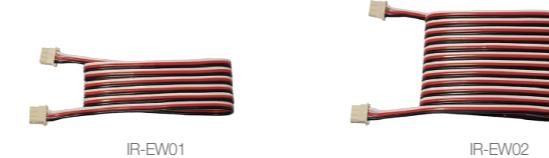

- IR-EW03 : **2,000mm** length with **4pins RS-485** Molex connectors (51065-0400)
- IR-EW04 : **4,000mm** length with **4pins RS-485** Molex connectors (51065-0400)



Optional Accessories

End Bearing IR-EB01

Mount mightyZAP servo on applications using this end-bearing for most optimal installation. Put it on the Rod-end(M3) and on the end of mightyZAP servo case (M2.5).

Two end bearings (M3 and M2.5) to be packed in a set.

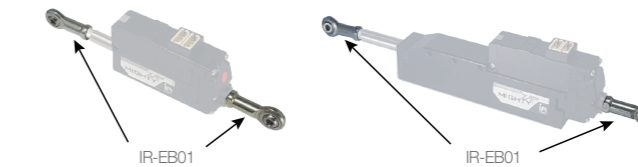

Metal Bracket IR-MB02

Mounting bracket IR-MB02 is dedicated for 26/27mm stroke line-up.

Referring to the published drawings, user is also able to make this bracket at their end if necessary.

Metal Bracket IR-MB03

Mounting bracket IR-MB03 is dedicated for IR-MB03 is for 40 to 96mm stroke line-up.

Referring to the published drawings, user is also able to make this bracket at their end if necessary.

40 to 96mm stroke line-up can be installed through the tapped hole of the body without bracket according to application.

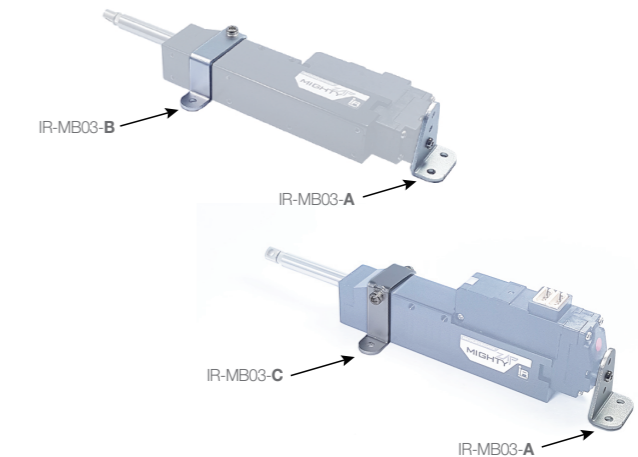

Optional Accessories

PC USB Interface IR-USB01

The IR-USB01 is the interface board which connects mightyZAP servo with user's PC so that user is able to do various tasks shown below.

- Operation parameters and memory parameter setting
- Simple Motion Test
- System initialization and Firmware update
- Voltage, Load, Temperature, Present position monitoring



Servo Tester Shield IR-STS01

Control mightyZAP servo motions without PC software.

Built with Arduino Leonardo and our own servo shield, user controls servo motor using Arduino API & libraries.



Raspberry Pi HAT(Hardware Attached on Top) IR-STS02

IR-STS02 is a Raspberry Pi add-On board which is compatible with Raspberry Pi B3 or Raspberry Pi Zero.

With TTL/RS-485/PWM communication interface, power connector and GPIO pins, user is able to control mightyZAP servo on Raspberry Pi. API and Library can be downloaded from our web.

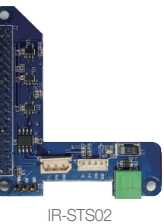

EZ Controller IR-CT01

- mightyZAP controller/tester for customers who do not have their own controller
- Arduino based simple operation
- Built-in basic control program, User programmable (Arduino example provided)
- Built-in position setting dials, position command button switches and position command slide
- Controllable through external switch or voltage level signal
- 6 x I/O pins for analog/digital sensor connection
- External communication terminal for Bluetooth or Zigbee communication

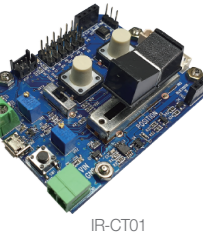

MINI, BUT MIGHTY.

Position Control

- Micro Size with Built-in Drive Circuit
- Precision position accuracy (30~50µm)
- Data Communication and Position Feedback
- Stroke Options (26 to 96mm)
- Rated Load Options (6 to 100N)
- Speed Options (7.7 to 110mm/sec)



Size Comparison



Dimension (Cored Motor Lineup)

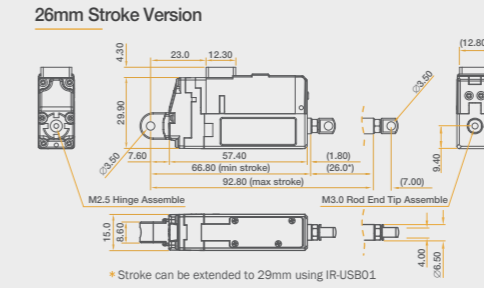

In case that our standard actuator does not meet your requirement, Please feel free to contact us to inquire customization.

Benefits for corporate customers

- Quantity Discount program
- Customization
- Instant technical support

- Micro Size with Built in Drive Circuit
- Precision position accuracy (30~50µm)
- Data Communication and Position Feedback
- Stroke Options (26 to 96mm)
- Rated Load Options (6 to 100N)
- Speed Options (7.7 to 110mm/sec)

www.irrobot.com
Head Office : 401-1303, 655, Pyeongcheon-ro, Bucheon-si, Gyeonggi-do, Korea (Zip 14502)

MINI, BUT MIGHTY.

Managing Director
Daniel (Hyun-Bo) Hwang
☎ +82-70-7600-9471
✉ irsales@irrobot.com

IR ROBOT
IR ROBOT CO., LTD.

+82-32-326-3466
+82-32-326-3468

Dimension (Coreless Motor Lineup)

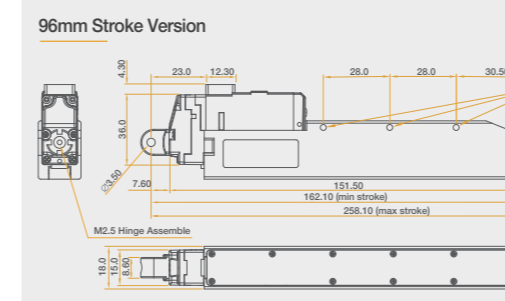
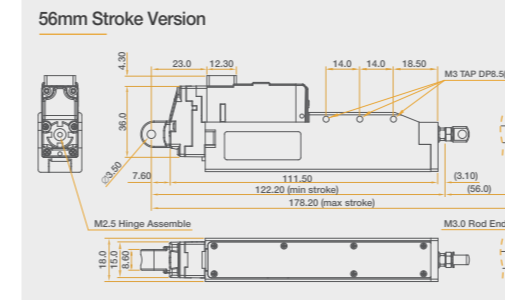
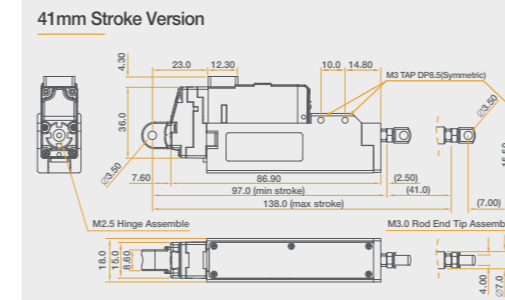
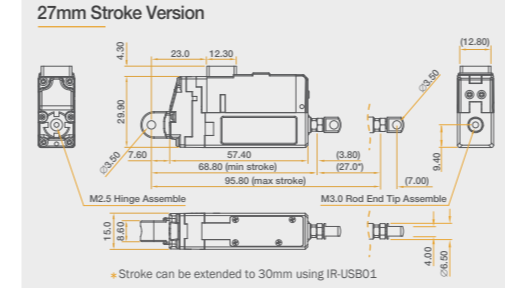

Specification Chart

Motor Voltage	Communication	Force 12N	Rated Load 20N	Rated Load 17N			Rated Load 40N	Rated Load 31N		
		27mm Stroke	27mm Stroke	41mm Stroke	56mm Stroke	96mm Stroke	27mm Stroke	41mm Stroke	56mm Stroke	96mm Stroke
12V	RS-485	L12-12F-3	L12-20F-3	L12-20F-4	L12-20F-6	L12-20F-10	L12-40F-3	L12-30F-4	L12-30F-6	L12-30F-10
	TTL/PWM	L12-12PT-3	L12-20PT-3	L12-20PT-4	L12-20PT-6	L12-20PT-10	L12-40PT-3	L12-30PT-4	L12-30PT-6	L12-30PT-10
Applicable Max Load / Max. Speed(No Load)		24N / 110.0mm/s	40N / 80.0mm/s	34N / 80.0mm/s			80N / 28.0mm/s	62N / 28.0mm/s		
Mechanical Self Lock (Z Axis Application)		Not Available		Not Available			Available			
Gear Ratio / Gear Type / Rod Type		10:1 / Engineering Plastic Gears / Metal Alloy Rod								
Motor Type / Watt		Coreless Motor / 26W								

Motor Voltage	Communication	Rated Load 6N			Rated Load 12N		
		26mm Stroke			26mm Stroke		
12V	RS-485	12V, RS-485			D12-6F-3		
	TTL/PWM	12V, TTL/PWM			D12-6PT-3		
7.4V	RS-485	7.4V, RS-485			D7-6F-3		
	TTL/PWM	7.4V, TTL/PWM			D7-6PT-3		
Applicable Max Load / Max. Speed(No Load)		12N / 36mm/s			24N / 12mm/s		
Mechanical Self Lock (Z Axis Application)		Not Available			Available		
Gear Ratio / Gear Type / Rod Type		10:1 / Engineering Plastic Gears / Engineering Plastic Rod					
Motor Type / Watt		Cored Motor / 4.2W					

Common Specification

	Stroke	Unidirectional		Wire Harness (Molex to S-02 PWM wire to be packed in Cored Motor Version only)	PWM/TTL(PT version) : Molex to S-02 and Molex to Molex Type (Molex 50-37-5033, 3pins) / 200mm length, 0.08x60(22AWG) or RS-485(F version) : Molex to Molex Type (Molex 0510650400, 4pins) / 200mm length, 0.08x60(22AWG)G
		26mm / 27mm / 41mm	30µm (0.03mm)		
Positional Accuracy	56mm	40µm (0.04mm)			
	96mm	50µm (0.05mm)			
Mechanical Backlash	0.03mm (30µm)		Position Sensor	10KΩ linear Potentiometer	
Input Voltage Range	7 ~ 13V for 12V Motor, 6.5~8.9V for 7.4V Motor		Data Communication / Protocol	RS-485 or TTL(PT version) / IR Robot open protocol	
LED Indication	7 Error Indications (Overload, Checksum, Data Range, Overheat, Stroke Limit, Input voltage, Instruction Error)		Pulse Signal / Pulse Range	PWM (PT version, Used in RC model hobby) / 900µs(Retracted)-1500µs(Center)-2100µs(Extended)	
			Operating Temperature	-10°C ~ 60°C	
Recommend Duty Cycle	At rated Load		Ingress Protection	IP-54 (Dust & Water Tight)	
	Max 50%		Audible Noise	Approx. 50db at 1m	
Current Consumption	At applicable Max Load		Size / Weight (Excluding rod-end & hinge)	26/27mm	57.4(L)x29.9(W)x15(H)mm / 49~52g
	7.4V	Max 20%		Max 20%	41mm
Cored	Idle	Rated	Stall	56mm	111.5(L)x36(W)x18(H)mm / 124~127g
	30mA	250mA	0.48A	96mm	151.5(L)x36(W)x18(H)mm / Approx. 177g
	30mA	250mA	0.48A		
Coreless	Idle	Rated	Stall		
	30mA	250mA	0.48A		
	20mA	380mA	1.6A		

* Design and Specification can be changed without prior notice for further improvement.